

8 Amp current transducer RAZ3-802A range

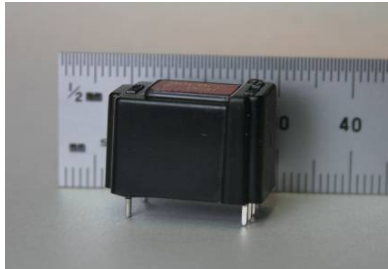

This new Hall Effect Current Transducer retains the excellent linearity and low hysteresis of our 2nd Generation parts, but adds laser-trimmed calibration accuracy and a convenient machine-insertable package.

RAZ3 parts can replace closed-loop current sensors in many applications.

Features –

- Small-footprint UL94-V0 rated package
- Line voltage isolated
- High measuring circuit dv/dt rejection – suitable for PWM controllers
- Gains compatible with 12 bit ADC (1 lsb = 10mA) or Analog (100mV/A)
- Highly accurate null-trimming for current-control applications
- 5% gain accuracy

Maximum Ratings ($T_A = 25^\circ\text{C}$)

Parameter	Symbol	Value	Unit
Operating Temperature	T_A	-40 to +85	$^\circ\text{C}$
Storage Temperature	T_{stg}	-65 to +170	$^\circ\text{C}$
Supply Voltage	V_S	8	V
Maximum measuring-circuit current	I_{max}	10	A

Characteristics (TA = 25°C, except where stated)

Parameter	Symbol	Lower Limit	Typical	Upper Limit	Unit
Measured current range (-40 to +85 °C)	I _P		±8.0		A
Measuring Circuit insertion resistance (excluding PCB tracks)	R _p		6		mΩ
Measuring Circuit insertion inductance (excluding PCB tracks)	L _p		3.75		μH
Resolution (Gain code <i>A or B</i>) with 5.0V (user supplied) 12-bit ADC (lsb magnitude)	δI		10		mA
Supply Current	I _s		6.6	9	mA
Supply Voltage	V _s	4.5	5.0	5.5	V
Null Output (V _s = 5.00V)	V _o	Tolerance code F	2.496	2.504	V
		Tolerance code G	2.492	2.508	
		Tolerance code H	2.484	2.516	
Transfer Function (V _s = 5.00V, Gain Code <i>A or B</i>)	ΔV/I	Tolerance Code F = 1%	120..9	123.3	mV/A
		Tolerance Code G = 2%	119.6	124.6	
		Tolerance Code J = 5%	116.0	128.2	
<i>Transfer Function (V_s = 5.00V, Gain Code <i>C or D</i>)</i>	<i>ΔV/I</i>	<i>Tolerance Code F = 1%</i>	99.0	101.0	<i>mV/A</i>
		<i>Tolerance Code G = 2%</i>	98.0	102.0	
		<i>Tolerance Code J = 5%</i>	95.0	105.0	
Non-linearity (±8.0A, -40 to +85 °C)			1	1.5	%
Hysteresis (0 to 5.0A)	Hys		0.1	0.25	%
Null drift due to temperature change (as equivalent current)	TC _{ΔI/ΔT}	Continuous Cal. [†]	±0.5	±2	mA/K
		Pulsed Calibration	±2	±5	
Gain Change due to temperature change	TC _G		±0.05		%/K
Risetime 0 to 2.0A	Tr		15		μs

Standards

EN50178 (1997)

* = 5.00V/4096 x 100, based on least-significant bit of 12-bit ADC corresponding to 10mA measurement.

† Continuously calibrated recommended for most applications, Pulse Calibrated for battery powered applications.

Characteristics (TA = 25°C) Continued

Parameter	Symbol	Lower Limit	Typical	Upper Limit	Unit
Output Resistance – Gain Codes B or D (Buffered) Gain Codes A or C	R _o	100	150	350 20	Ω
Effect of primary dv/dt (Equivalent measured Ampères/(Primary Volts/second) – for PWM applications) Gain Codes B or D (Buffered) Gain Codes A or C			10 ⁻⁹ 10 ⁻¹⁰		AV ⁻¹ s
Noise	E _{nrms}			2.5	mV rms
Creepage/Clearance Distance		14			mm
Mass			6.5		g
Fire Resistance rating			UL94-V0		

Standards

EN50178 (1997)

Connections –

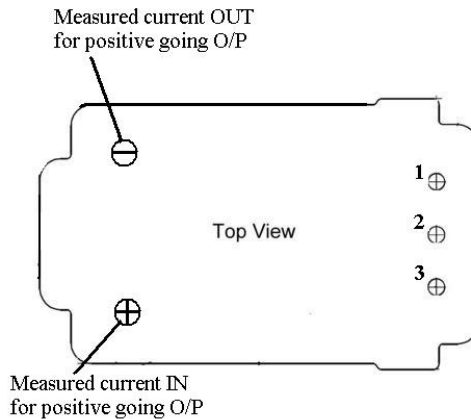

Footprint looking onto mounting surface

Secondary Pins -

- 1 +5V supply
- 2 0V common
- 3 Output

Options

- Fast settling versions for pulsed 5V supply (e.g. Battery supplied applications)

Mechanical

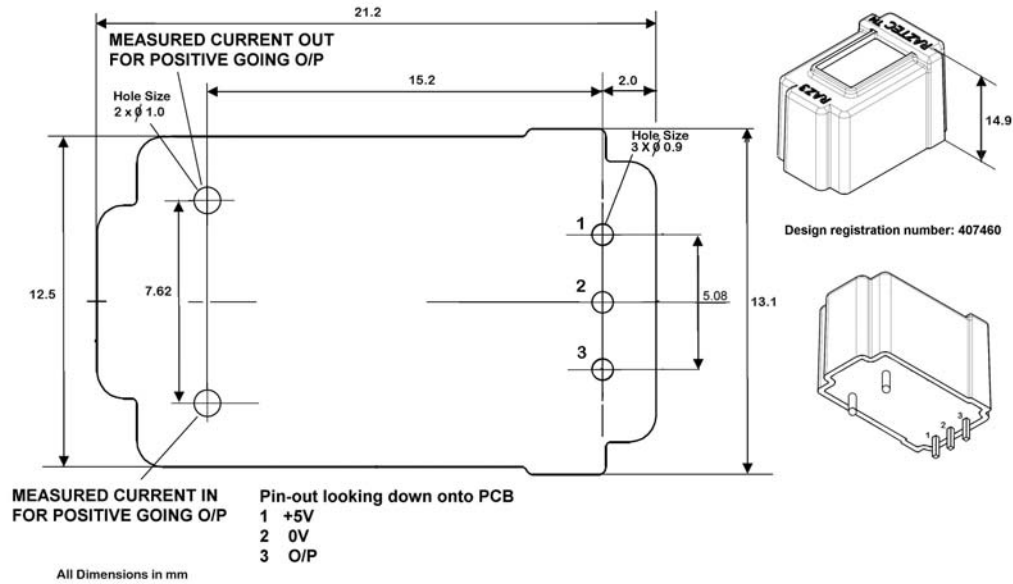

Footprint looking onto mounting surface – dimensions in mm

Part Numbering System

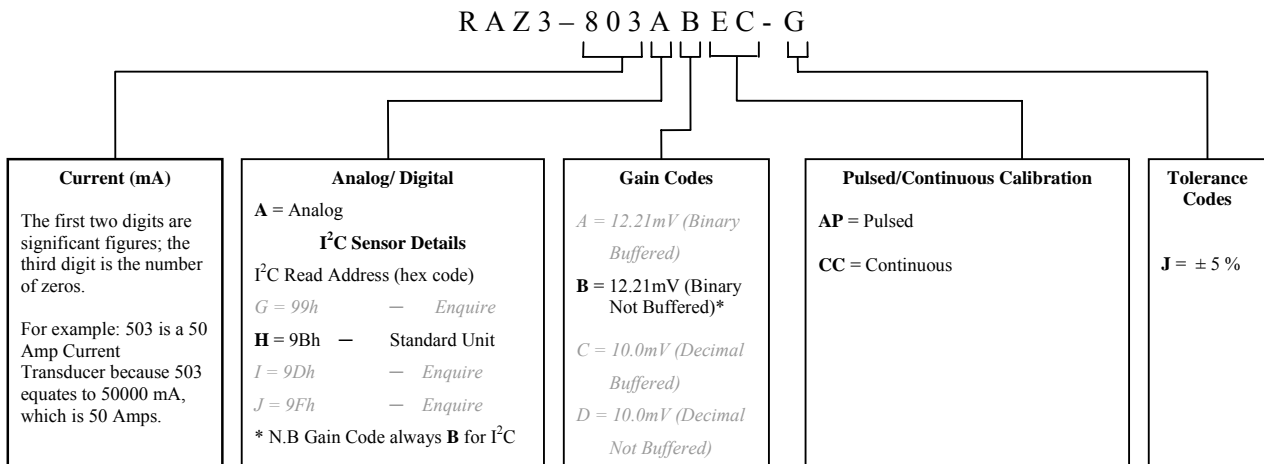

Options – enquire with factory prior to order

Performance characteristics

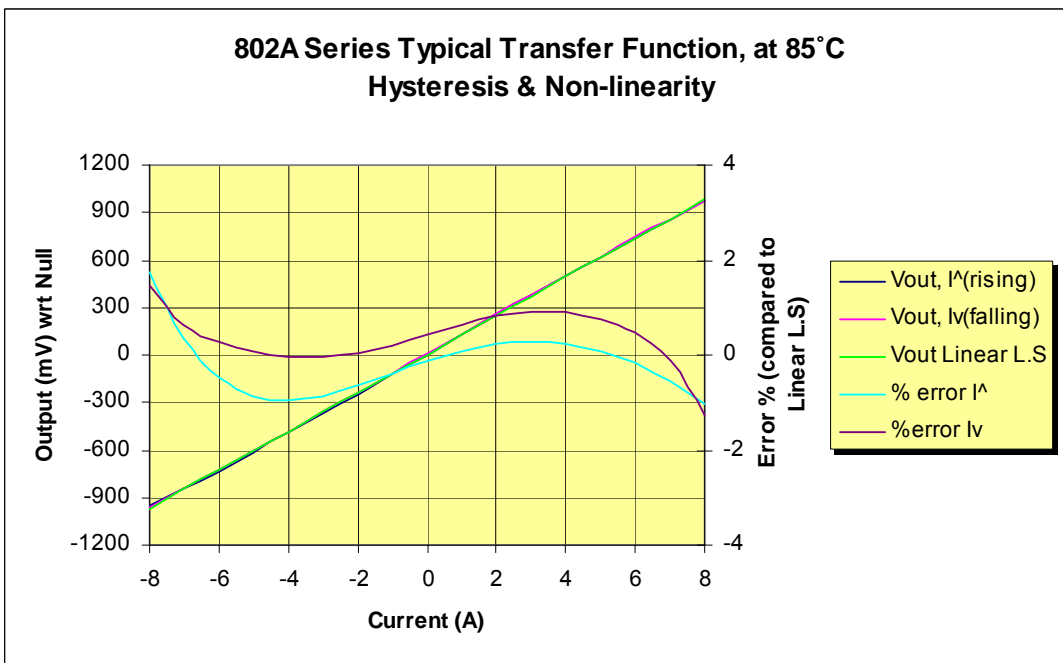
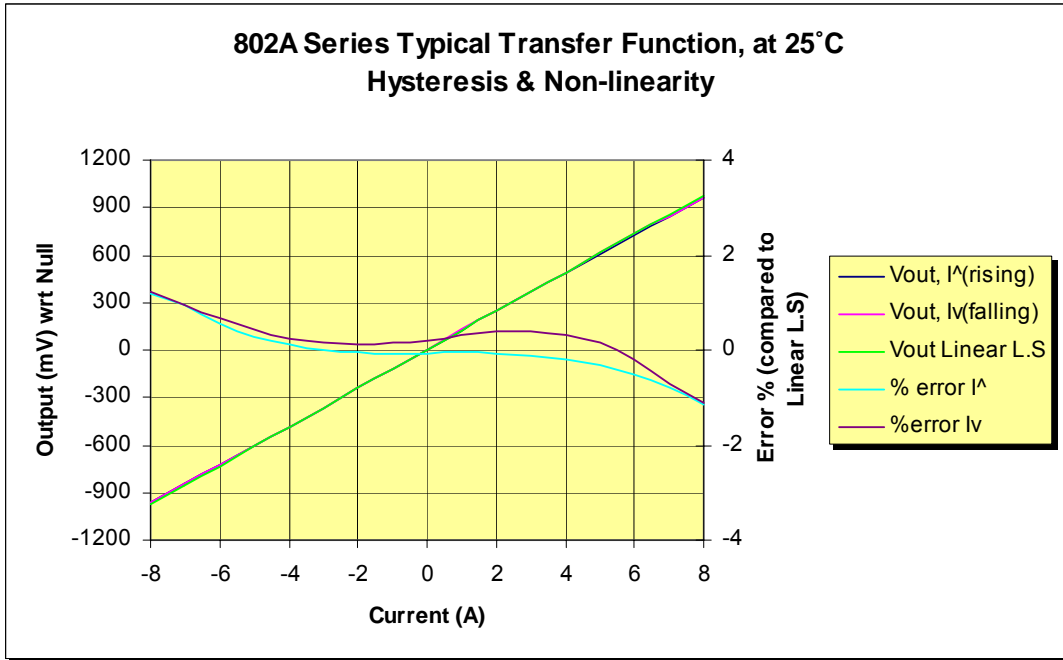

Raztec (NZ) Ltd operate a continuous product improvement program, therefore information contained in our datasheets may not reflect all current features. For clarification please contact sales@raztec.co.nz